

# 355nm Nd:YAG q-switched picosecond laser MD Microchip laser system

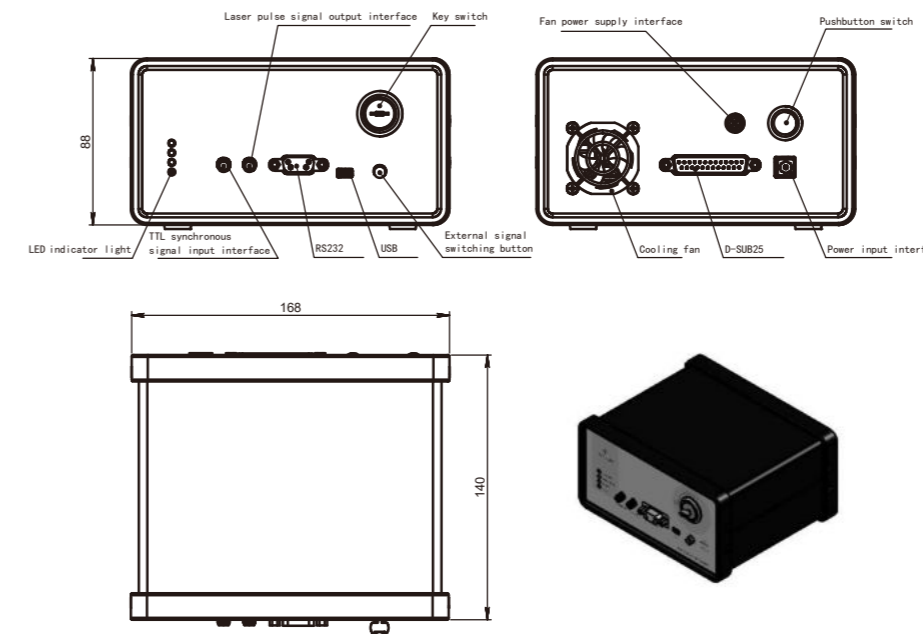

OUTLINE SIZE(mm)



## DESCRIPTION

Our 355nm laser is based on the technology of diode pump laser module and q-switch. Nd:YAG crystal is used to manufacture 355nm laser. Crylink can provide 1.5ns, 1ns, 500ps, 550ps and 300ps 355nm microchip laser.

Our 355nm microchip laser has narrow laser pulse width. At the same time, it has high pulse repetition frequency. As a microchip laser, its size is small and its weight is light certainly. Our laser's beam quality is excellent.

As a uv laser, 355nm microchip laser plays an important role in many fields. It can be used in environment monitoring systems, 3d dental scan, laser ultrasound, laser ionization mass spectrometry and so on.

## FEATURES

- Pulse width up to 550ps
- Pulse energy up to 120μJ
- High polarization direction stability
- Maximum repetition rate up to 10kHz
- Beam mode is TEM<sub>00</sub>
- Fully sealed design, high reliability

## APPLICATIONS

- Seed source
- Micromachining
- Fluorescence lifetime measurement
- Laser-induced fluorescence
- Laser ionization mass spectrometry
- Non-linear optical measurement

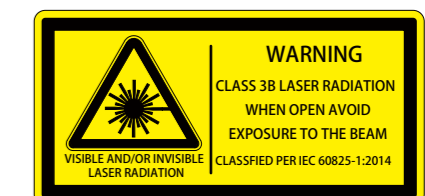
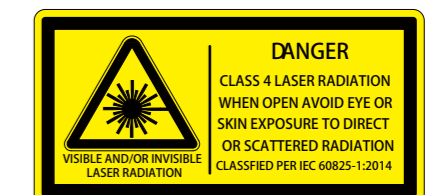
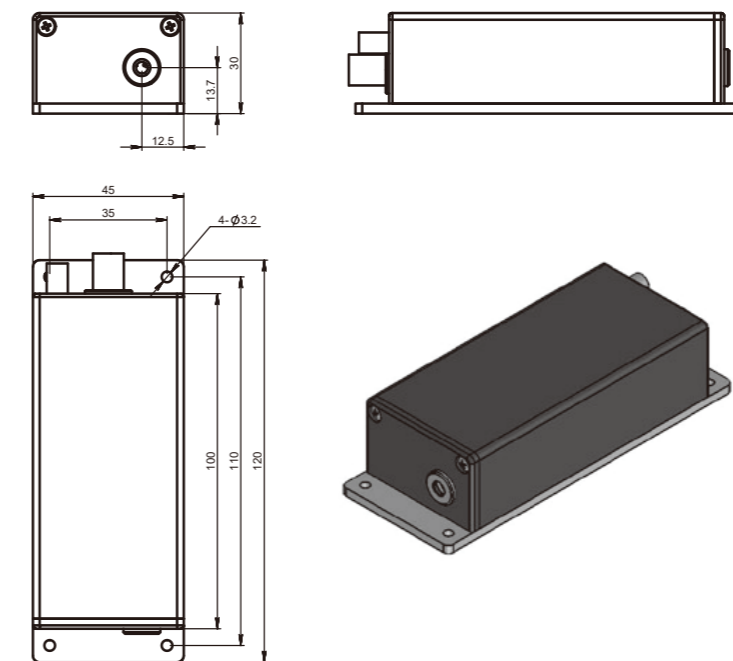

## PARAMETERS

Model	CL355-0.1kHz-15μJ-MD002	
Optical parameter	Wavelength (nm)	355
	Repetition frequency (kHz)	0.1*
	Average power(mW)	1.5
	Output energy(μJ)	15
	Pulse width (ps)	300
	Power stability (8h)	±3%
	Beam mode	TEM <sub>00</sub>
	Full-angle divergence angle Typ. (Mrad) level @1/e <sup>2</sup>	8
	Vertical @1/e <sup>2</sup>	8
	Polarization characteristics	> 100:1
System parameters	System power consumption (W)	≤25
	Power input	100-240 VAC,50/60Hz
	Control interface	RS232、USB
	Power supply size (W×H×L, mm)	168×88×140
	Laser head size (W×H×L, mm)	45×30×120
	Working temperature (°C)	15-35
	Storage temperature (°C)	0-60

1.\*The light outlet of the laser head is side outlet. See the mechanical dimension drawing for details

2.Customized internal beam expansion function to meet the requirements of small divergence angle (less than 2mrad)

