

266nm Nd:YAG q-switched picosecond laser MD Microchip laser system



DESCRIPTION

266nm laser is one of the series of solid state laser provided by Crylink. It is based on the Nd:YAG crystal. Crylink especially recommends our 266nm picosecond laser including of 2000ps, 550ps, 750ps and 350ps ones. If you need others, you can consult our sale staffs.

Our 266nm laser has pure and stable pulse. Thus, it has very high quality in pulse beam. Besides, it is a compact laser which is easy in install and integrate. Though our 266nm is a microchip laser which has small size and light weight, it is still a high energy laser.

Our 266nm laser has wide applications in the various walks of life. It can be used in micromachining, time resolved Raman spectroscopy, laser ultrasound, laser induced breakdown spectroscopy and so on.

FEATURES

- Pulse width up to 300ps
- Pulse energy up to 150μJ
- Beam mode is TEM₀₀
- High polarization direction stability
- Maximum repetition rate up to 1kHz
- Fully sealed design, high reliability

APPLICATIONS

- Seed source
- Laser micromachining
- Laser ionization mass spectrometry
- Nonlinear optical measurement
- Laser induced fluorescence
- Laser induced breakdown spectroscopy

OUTLINE SIZE(mm)

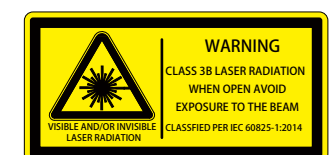
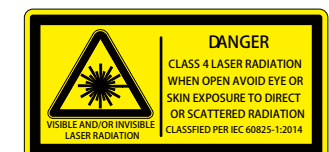
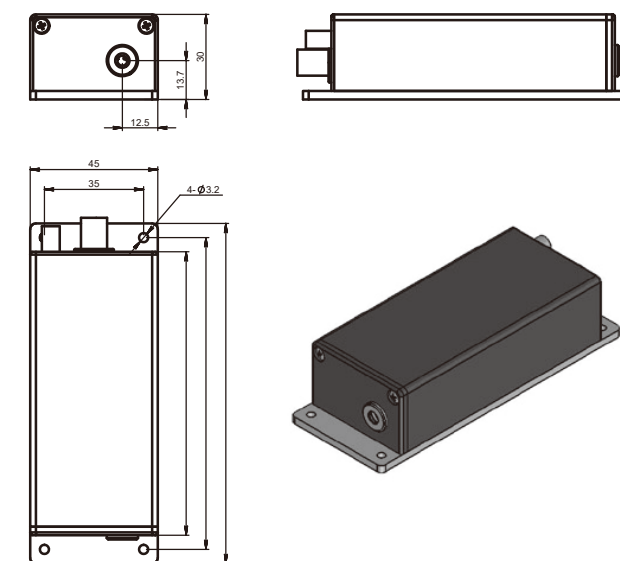
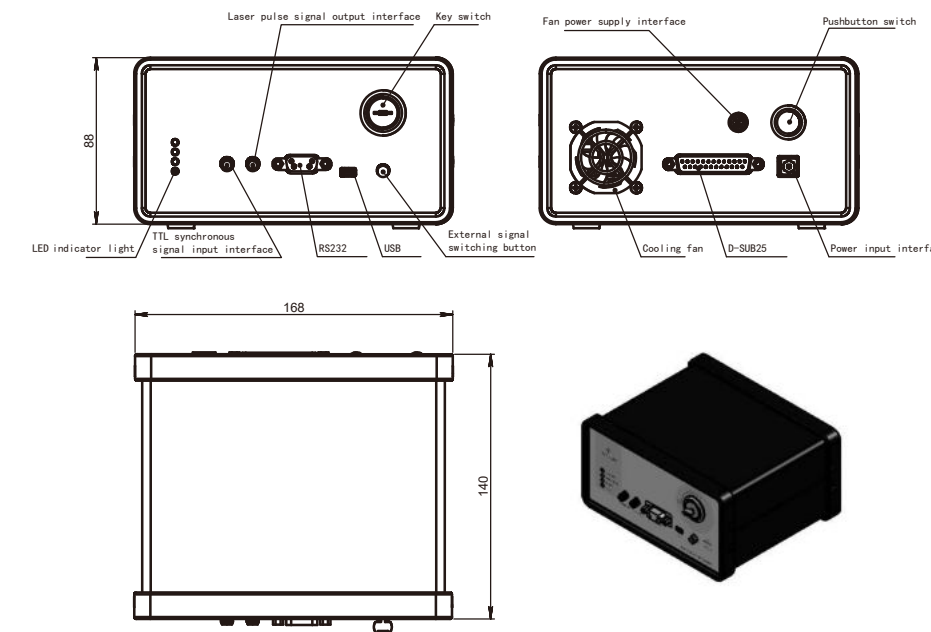

PARAMETERS

| | | |
|-------------------|---|----------------------|
| Model | CL266-0.1kHz-5μJ-MD001 | |
| Optical parameter | Wavelength (nm) | 266 |
| | Repetition frequency (kHz) | 0.1* |
| | Average power (mW) | 0.5 |
| | Output energy (uJ) | 5 |
| | Pulse width (ps) | 300 |
| | Power stability (8h) | ±3% |
| | Beam mode | TEM ₀₀ |
| | Full-angle divergence angle Typ. (Mrad) level @1/e ² | 8 |
| | Vertical @1/e ² | 8 |
| | Polarization characteristics | > 100:1 |
| System parameters | System power consumption (W) | ≤25 |
| | Power input | 100-240 VAC, 50/60Hz |
| | Control interface | RS232, USB |
| | Power supply size (W×H×L, mm) | 168×88×140 |
| | Laser head size (W×H×L, mm) | 45×30×120 |
| | Working temperature (°C) | 15-35 |
| | Storage temperature (°C) | 0-60 |

1.*The light outlet of the laser head is side outlet. See the mechanical dimension drawing for details

2.Customized internal beam expansion function to meet the requirements of small divergence angle (less than 2mrad)

