

266nm Nd:YAG q-switched picosecond laser MC Microchip laser system

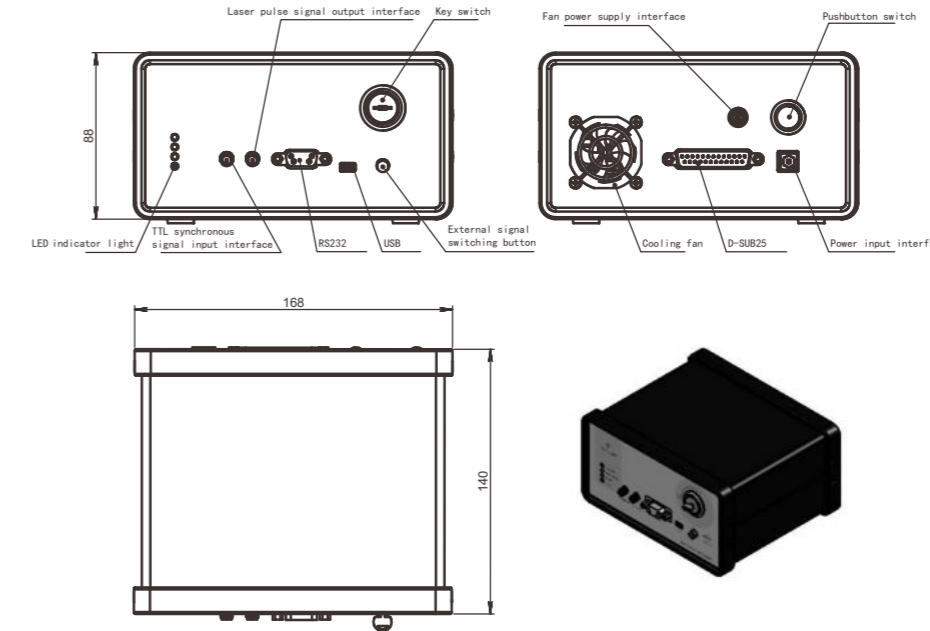

OUTLINE SIZE(mm)



DESCRIPTION

266nm laser is one of the series of solid state laser provided by Crylink. It is based on the Nd:YAG crystal. Crylink especially recommends our 266nm picosecond laser including of 2000ps, 550ps, 750ps and 350ps ones. If you need others, you can consult our sale staffs.

Our 266nm laser has pure and stable pulse. Thus, it has very high quality in pulse beam. Besides, it is a compact laser which is easy in install and integrate. Though our 266nm is a microchip laser which has small size and light weight, it is still a high energy laser.

Our 266nm laser has wide applications in the various walks of life. It can be used in micromachining, time resolved Raman spectroscopy, laser ultrasound, laser induced breakdown spectroscopy and so on.

FEATURES

- Pulse width up to 550ps
- Pulse energy up to 120μJ
- Beam mode is TEM₀₀
- High polarization direction stability
- Maximum repetition rate up to 10kHz
- Fully sealed design, high reliability

APPLICATIONS

- Seed source
- Laser ultrasonic testing
- Micromachining
- Pump source
- Laser induced fluorescence
- Laser ultrasonic image

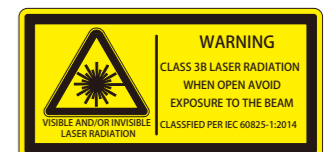
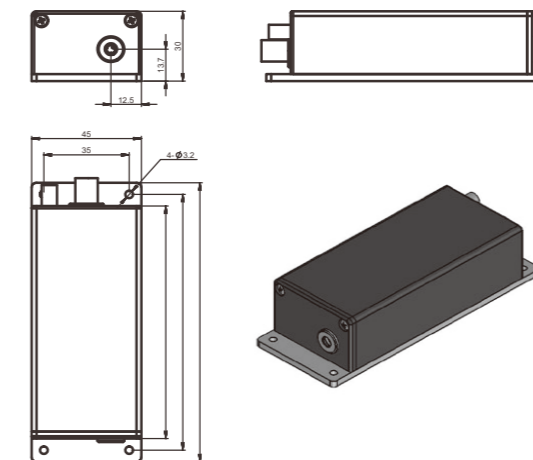

PARAMETERS

Model	CL266-1kHz-10μJ-MC002	CL266-5kHz-8μJ-MC003	CL266-10kHz-4μJ-MC004	
Optical parameter	Wavelength (nm)	266	266	266
	Repetition frequency (kHz)	1*	5*	10*
	Average power (mW)	10	40	40
	Output energy (μJ)	10	8	4
	Pulse width (ps)	650	650	650
	Power stability (8h)	±3%	±3%	±3%
	Beam mode	TEM ₀₀	TEM ₀₀	TEM ₀₀
	Full-angle divergence angle Typ. (Mrad) level @1/e ²	5	8	8
	Vertical @1/e ²	5	8	8
	Polarization characteristics	> 100:1	> 100:1	> 100:1
System parameters	System power consumption (W)	≤25	≤30	≤30
	Power input	100-240 VAC,50/60Hz	100-240 VAC,50/60Hz	100-240 VAC,50/60Hz
	Control interface	RS232, USB	RS232, USB	RS232, USB
	Power supply size (W×H×L, mm)	168×88×140	168×88×140	168×88×140
	Laser head size (W×H×L, mm)	45×30×120	45×30×120	45×30×120
	Working temperature (°C)	15-35	15-35	15-35
	Storage temperature (°C)	0-60	0-60	0-60

1.*The light outlet of the laser head is side outlet. See the mechanical dimension drawing for details

2.Customized internal beam expansion function to meet the requirements of small divergence angle (less than 2mrad)

