

520nm Optical Fiber Output Accurate Wavelength Laser Module of AWO Series

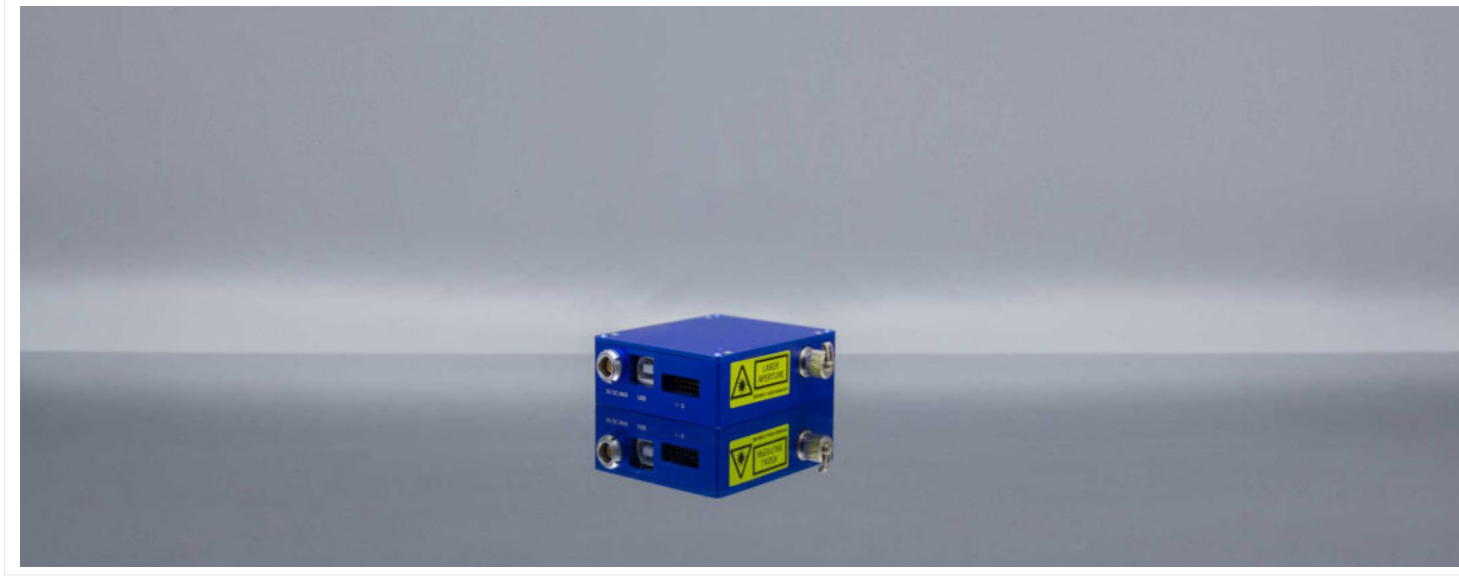

PARAMETERS

Model	CL520-SIF(FA)-28mW-AWO003	CL520-SIF(FP)-28mW-AWO004	
Optical Parameter	Central Wavelength (nm)	520	520
	Wavelength Tolerance (nm)	±10	±10
	Output Power (mW)	28	28
	Line Width (nm)	<6	<6
	Power Stability	±1.0% @8H	±1.0% @8H
System Parameter	Power Adjustment Range	0~100%	0~100%
	Preheat Time (Min)	15	15
	Modulation Input	PH2.0-10P	PH2.0-10P
	Fiber Interface	FC/APC	FC/PC
	Power Input	4.9~5.1	4.9~5.1
	System Power Consumption (W)	<4	<4
	Storage Humidity (RH)	0~80%	0~80%
	Storage Temperature (°C)	0~55	0~55
	Operating Temperature (°C)	10~35	10~35
	System Weight (g)	<130	<130
System Size (mm)	76.2×63.5×22	76.2×63.5×22	

DESCRIPTION

The quasi wavelength semiconductor laser module introduced by our company has a variety of wavelengths to choose from, equipped with standard input / output interface, which can be easily embedded into the user's whole system and achieve stable power output. This series of products adopt optical fiber coupling output mode, equipped with TEC refrigeration module, can provide customized and secondary development services according to customer requirements.

FEATURES

- Power stability is better than ± 1% @ 8H
- Built-in TEC, typical power consumption <4W
- Small size, 76.2 × 63.5 × 22mm
- Optional USB control interface, hardware lock

APPLICATIONS

- Fluorescence Spectrometer
- Laser particle size analyzer
- Flow cytometry
- Confocal microscope
- Raman spectrometer

OUTLINE SIZE(mm)

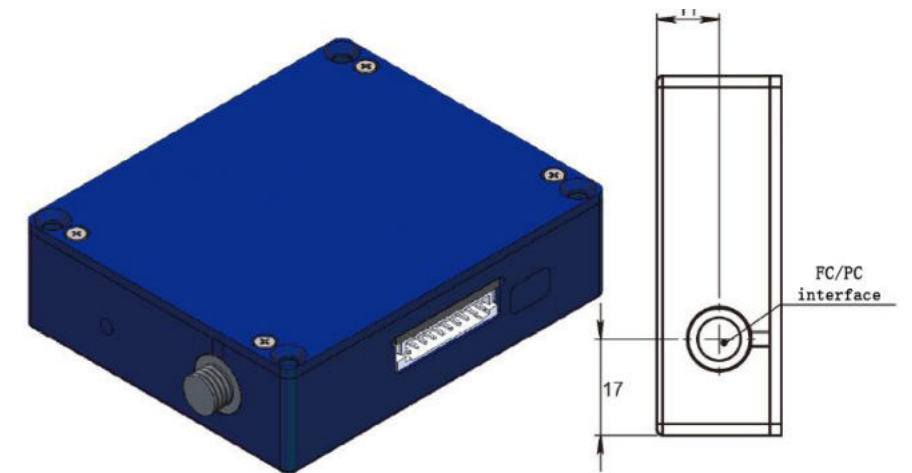
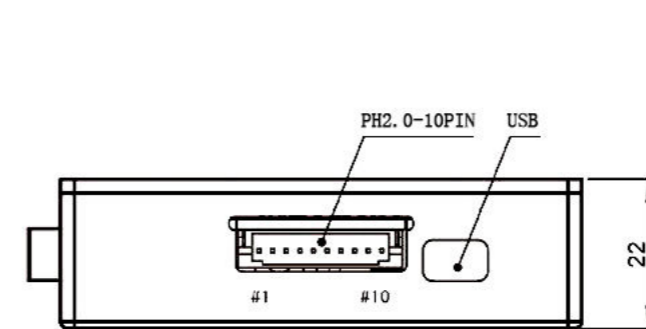
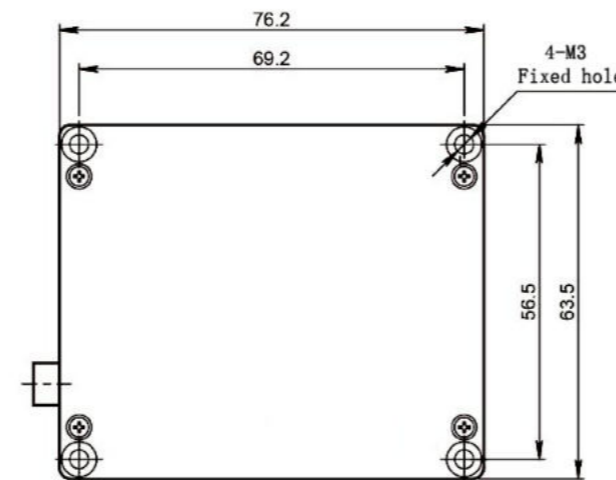

Unit:mm

